

**DOOSAN**



# Lynx 2100 series

6/8/10-Inch Global Compact Turning Center

**Lynx 2100 series**

Lynx 2100/M

Lynx 2100L/LM/



**MACHINE  
GREATNESS™**

**Basic information**

Basic Structure  
Cutting  
Performance

**Detailed Information**

Options  
Applications  
Diagrams  
Specifications

**Customer Support Service**



# Lynx 2100 series

The Lynx 2100 Series – the next generation of the Lynx Series, currently with more than 25000 sales worldwide – aims to deliver even greater customer satisfaction with its superior machining performance, reliability, and user convenience.

## Contents

### 02 Product Overview

#### Basic Information

04 Basic Structure

08 Cutting Performance

#### Detailed Information

09 Standard / Optional Specifications

11 Applications

14 Diagrams

24 Machine / CNC Specifications

30 Customer Support Service



### Superior Machining Performance

Equipped with a 15 kW (20.1 Hp) high-power motor and machine structure, and further enhanced spindle and axis ball screw stiffness, the Lynx 2100 Series offers excellent cutting capability up to a maximum turning diameter of  $\varnothing 350$  mm ( $\varnothing 13.8$  inch) and a maximum turning length of 550 mm (21.7 inch).

### High Reliability

The Series' excellent reliability is based on the adoption of a wider support structure, more stable bed, low vibration/noise spindle, servo-driven turret, and a full slideway cover for preventing coolant leaks and chips from penetrating the machine.

### Improved User Convenience

The CNC tailstock, new Easy Operation Package (EOP) and hot keys enable the user to operate peripheral devices quickly and conveniently. User convenience has been further enhanced with grease type lubrication and a lateral / rear side double-purpose chip conveyor.

## Basic Structure

### Basic information

Basic Structure  
Cutting  
Performance

### Detailed Information

Options  
Applications  
Diagrams  
Specifications

### Customer Support Service

The Lynx 2100 Series includes a wider support structure for X, Z axes and tailstock traverse. The X and Z axes are fitted with highly rigid roller-type LM Guideways.

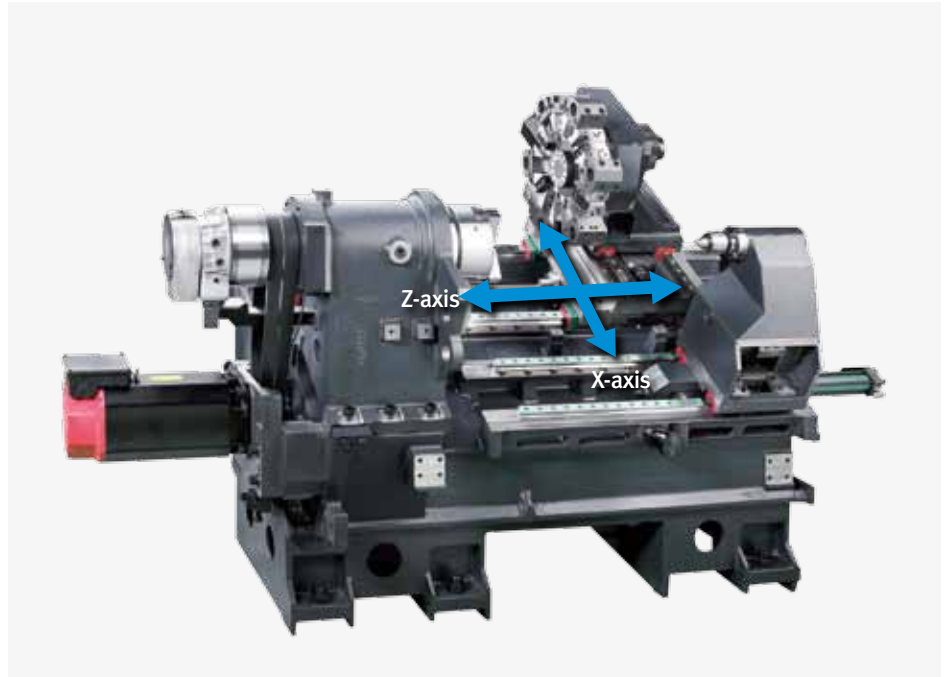

Standard chuck size	Models	Travel mm (inch)		Rapid feedrate m/min (ipm)		Functions		
		X-axis	Z-axis	X-axis	Z-axis	2-axis	M	MS
6 inch	Lynx 2100A / MA	205 (8.1)	340 (13.4)	30 (1.2)	36 (1.4)	○	○	-
	Lynx 2100LA / LMA / LMSA		560 (22.0)			○	○	○
8 inch	Lynx 2100B / MB	205 (8.1)	340 (13.4)	30 (1.2)	36 (1.4)	○	○	-
	Lynx 2100LB / LMB / LMSB		560 (22.0)			○	○	○
10 inch	Lynx 2100LC	205 (8.1)	560 (22.0)	30 (1.2)	36 (1.4)	○	○	○

\* M : 2-axis + Milling /  
MS : Milling + Sub spindle

## Largest Machining Area

The Series also offers the largest machining area window in its class, with a max. turning diameter of  $\varnothing 350$  mm ( $\varnothing 13.8$  inch) and a max. turning length of 550 mm (21.7 inch).

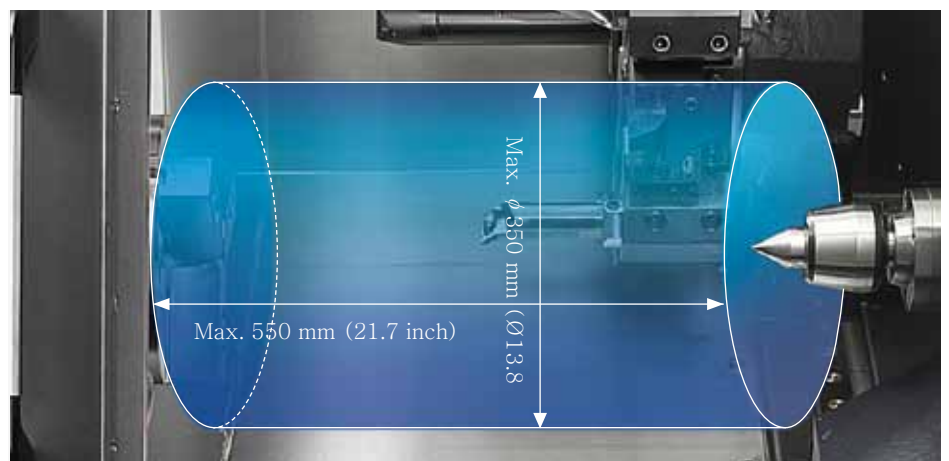

Function	Models	unit	Max. turning dia.	Bar working dia. (6inch / 8inch)	Max. cutting length
2-axis	Lynx 2100A / B	mm (inch)	$\varnothing 350$ ( $\varnothing 13.8$ )	51 / 65 (2.0 / 2.6)	330 (13.0)
	Lynx 2100LA / LB	mm (inch)	$\varnothing 350$ ( $\varnothing 13.8$ )	51 / 65 (2.0 / 2.6)	550 (21.7)
	Lynx 2100LC	mm (inch)	$\varnothing 350$ ( $\varnothing 13.8$ )	81 (3.2) (10 inch)	537 (13.0)
M / MS type	Lynx 2100MA / MB	mm (inch)	$\varnothing 300$ ( $\varnothing 11.8$ )	51 / 65 (2.0 / 2.6)	290 (11.4)
	Lynx 2100LMA / LMB	mm (inch)	$\varnothing 300$ ( $\varnothing 11.8$ )	51 / 65 (2.0 / 2.6)	510 (20.1)
	Lynx 2100LMSA / LMSB	mm (inch)	$\varnothing 300$ ( $\varnothing 11.8$ )	51 / 65 (2.0 / 2.6)	510 (20.1)
	Lynx 2100LMC/LMSC	mm (inch)	$\varnothing 300$ ( $\varnothing 11.8$ )	81 (3.2) (10 inch)	497 (19.6)

## Spindle

The high power / torque motor supports high-precision and heavy-duty cutting, improving productivity.



Max. Speed  
**6000 r/min (6 inch)**

Max. Torque  
**269 N·m (10 inch)**  
**(198.5 ft-lbs)**

Standard chuck size	Models	Spindle speed r/min	Max.power (15min/cont.) kW (Hp)	Max torque N·m (ft-lbs)
6 inch	Lynx 2100A / LA / MA / LMA / LMSA	6000	15/11 (20.1/14.7)	127 (93.7)
8 inch	Lynx 2100B / LB / MB / LMB / LMSB	4500	15/11 (20.1/14.7)	169 (124.7)
10 inch	Lynx 2100LC / LMC / LMSC	3500	18.5/15 (24.8/20.1)	269 (198.5)

## Sub-spindle

The sub-spindle function enables rear-side cutting by a single setup, thereby maximizing the user's productivity and efficiency. Full C axis 0.001 degree control is included to optimize capability.

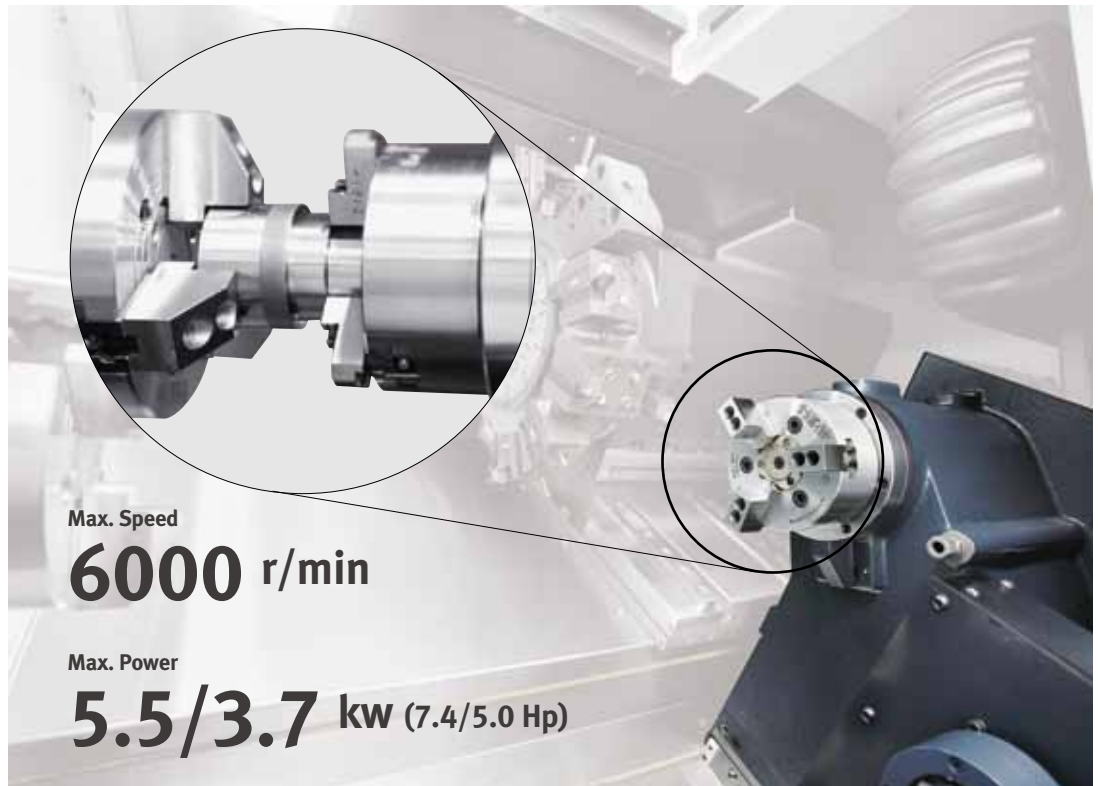

Max. Speed  
**6000 r/min**

Max. Power  
**5.5/3.7 kw (7.4/5.0 Hp)**

Models	Standard chuck size	Spindle speed r/min	Max.power (15min/cont.) kW	Max torque N · m (ft-lbs)
Lynx 2100LMSA / LMSB /LMSC	5 inch	6000	5.5 / 3.7 (7.4 / 5.0)	47 (34.7)



**Turret**

**Turret for 2-axis Models\_ Lynx 2100A / B / LA / LB / LC**

**Basic information**

- Basic Structure
- Cutting
- Performance

**Detailed Information**

- Options
- Applications
- Diagrams
- Specifications

**Customer Support Service**

Rotation of the turret is controlled by servo motor for rapid and accurate selection of tools. The M model is fitted with Doosan's unique BMT45P turret to provide superior performance for milling operations.



**No. of Tool Positions**

Lynx 2100A/LA/B/LB

Lynx 2100LC

**10 station** option

**10 station**

**12 station**

**12 station** option

**BMT45P Turret for M/MS Models\_ Lynx 2100 MA / MB / LMA / LMB / LMC / LMSA / LMSB / LMSC**

The BMT45 turret developed using Doosan's unique technology minimizes thermal error by using an air / oil cooling system. The direct turret clamping system improves accuracy and rigidity.



**No. of Tool Positions**

**Indexing**

**12 station**

**24 position index**

## Tailstock

Adoption of the hydraulic actuation type CNC tailstock (hydraulic type) enables tailstock positioning and work setting using the operation panel. The dedicated screen reduces the work setting time by about 50%.

### CNC Tailstock (Hydraulic Type)

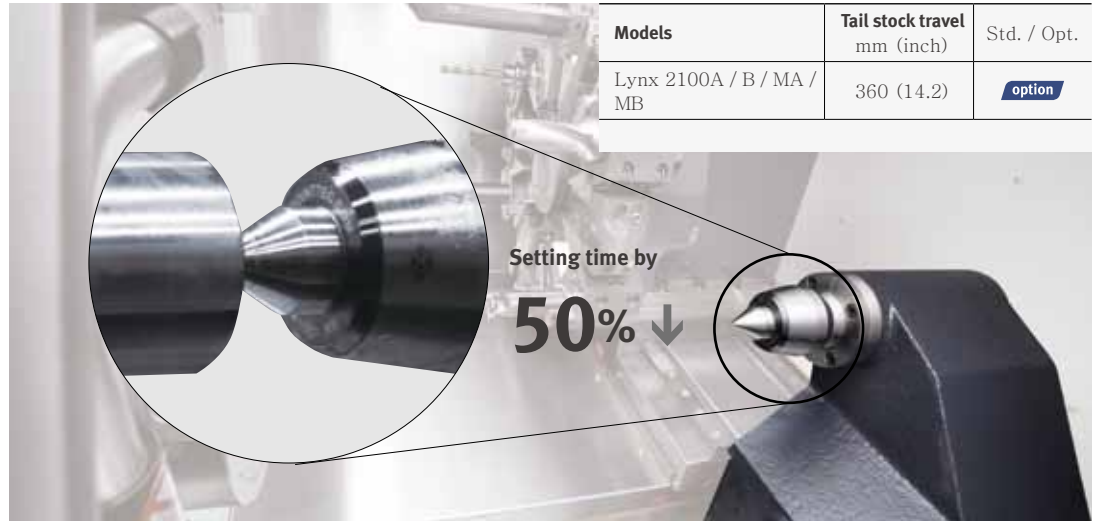

Models	Tail stock travel mm (inch)	Std. / Opt.
Lynx 2100A / B / MA / MB	360 (14.2)	<b>option</b>



The EOP (Easy Operation Package) System enables fast and easy tailstock position setting and control.

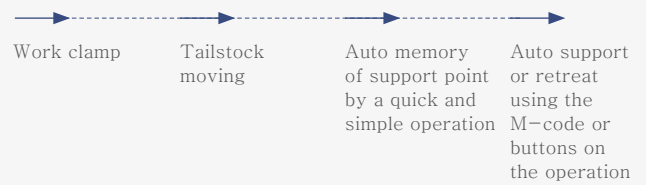

## Doosan Gantry Loader

Doosan Gantry Loader is compact and easy customized stand alone type automation solution controlled by motion controller.



- \* Operational flexibility with motion controller
  - Interfaces with two or more machines
  - Separate system from main machine

Description		Unit	Doosan Gantry Loader
Travel	Z / Y axis	mm (inch)	2080 / 900 (81.9 / 35.4)
Rapid Traverse	Z / Y axis	m/min (ipm)	210 / 180 (8267.7 / 7086.6)
Work Capacity		mm (inch)	Ø150 x 90 (Ø5.9 x 3.5)
		kg (lb)	3 (6.6)
Number of Pallets (Work Stocker)		st	14
Applicable model		-	Lynx 2100 series / PUMA GT2100 series

## Cutting Performance

### Basic information

Basic Structure  
Cutting  
Performance

Lynx 2100 series has powerful cutting performance.

### Detailed Information

Options  
Applications  
Diagrams  
Specifications

### Customer Support Service



O.D turning		
	Unit	Lynx 2100LB
Cutting speed	m/min (ipm)	210 (8267.7)
Feed	mm/rev (ipr)	0.56 (0.0)
Spindle speed	r/min	844
Cutting depth	mm (inch)	4 (0.2)



I.D turning (Rough / End)		
	Unit	Lynx 2100LB
Cutting speed	m/min (ipm)	280 / 200 (11023.6 / 7874.0)
Feed	mm/rev (ipr)	0.3 / 0.1 (0.0 / 0.0)
Spindle speed	r/min	1182 / 863
Cutting depth	mm (inch)	3 / 0.4 (0.1 / 0.0)



U-drilling		
	Unit	Lynx 2100LB
Cutting speed	m/min (ipm)	200 (7874.0)
Feed	mm/rev (ipr)	0.12 (0.0)
Spindle speed	r/min	1011
U-drill dia.	mm (inch)	63 (2.5)
Cutting depth	mm (inch)	176 (6.9)



Face milling		
	Unit	Lynx 2100MA
Cutting speed	m/min (ipm)	188 (7401.6)
Feed	mm/min (ipm)	600 (23.6)
Spindle speed	r/min	1500
Cutting depth	mm (inch)	3 (0.1)
Chip removal rate	cm <sup>3</sup> /min (inch <sup>3</sup> /min)	57.6 (3.5)



End milling		
	Unit	Lynx 2100MA
Cutting speed	m/min (ipm)	57 (2244.1)
Feed	mm/min (ipm)	300 (11.8)
Spindle speed	r/min	1500
Cutting depth	mm (inch)	30 (1.2)
Chip removal rate	cm <sup>3</sup> /min (inch <sup>3</sup> /min)	108 (6.6)



Tap		
	Unit	Lynx 2100MA
Tap dia.	mm (inch)	10 (0.4)
Cutting speed	m/min (ipm)	60 (2.4)
Feed	mm/rev (ipr)	1.75 (0.1)
Spindle speed	r/min	1592

\* The results, indicated in this catalogue are provides as example. They may not be obtained due to differences in cutting conditions and environmental conditions during measurement.



## Standard / Optional Specifications

Various optional features are available for customer-specific work environments.

● Standard ○ Optional ✕ Not applicable

NO.	Description	Features	Lynx 2100A/LA	Lynx 2100B/LB	Lynx 2100LC	Lynx 2100MA/LMA/LMSA	Lynx 2100MB/LMB/LMSB	Lynx 2100LMC/LMSC
1	Chuck	6 inch	●	✕	✕	●	✕	✕
2		8 inch	○	●	✕	○	●	✕
3		10 inch	✕	○	●	✕	○	●
4		None	○	○	○	○	○	○
5	Jaw	Soft jaw	●	●	●	●	●	●
6		Hard jaw	○	○	○	○	○	○
7	Chucking option	DUAL PRESSURE CHUCKING	○	○	○	○	○	○
8		CHUCK CLAMP CONFIRMATION	●	●	●	●	●	●
9	Turret	Rotary tool_6000r/min	✕	✕	✕	●	●	●
10		Rotary tool_10000r/min	✕	✕	✕	○	○	○
11	Coolant pump	1.5 bar	●	●	●	●	●	●
12		4.5 bar	○	○	○	○	○	○
13		7 bar	○	○	○	○	○	○
14		10 bar	○	○	○	○	○	○
15		14.5 bar	○	○	○	○	○	○
16	Coolant pump (opt.)	4.5 bar	○	○	○	○	○	○
17	Coolant options	Oil Skimmer	○	○	○	○	○	○
18		Coolant chiller	○	○	○	○	○	○
19		Coolant pressure switch	○	○	○	○	○	○
20		Coolant level switch : Sensing level - Empty / Low / Enough / Full	●	●	●	●	●	●
22	Side chip conveyor	Hinged belt	○	○	○	○	○	○
23		Magnetic scrapper	○	○	○	○	○	○
24		Screw (auger)	○	○	○	○	○	○
25	Rear chip conveyor	Hinged belt	○	○	○	○	○	○
26		Magnetic scrapper	○	○	○	○	○	○
27		Screw (auger)	○	○	○	○	○	○
28	Chip bucket	Forklift 110L (for auger conveyor)	○	○	○	○	○	○
29		Forklift 200L (for auger conveyor)	○	○	○	○	○	○
30		Forklift 220L	○	○	○	○	○	○
31		Forklift 300L	○	○	○	○	○	○
32		Forklift 380L	○	○	○	○	○	○
33		Rotation 220L	○	○	○	○	○	○
34		Rotation 300L	○	○	○	○	○	○
35		Rotation 380L	○	○	○	○	○	○
36	Chip processing options	Air blower	○	○	○	○	○	○
37		Chuck coolant	○	○	○	○	○	○
38		Coolant gun	○	○	○	○	○	○
39		Mist collector ready	○	○	○	○	○	○
40	Assembled mist collector	○	○	○	○	○	○	
41	Measurement & Automation	Bar feeder system	○	○	○	○	○	○
42		Auto door	○	○	○	○	○	○
43		Tool setter (Manual)	○	○	○	○	○	○
44		Tool setter (Auto)	○	○	○	○	○	○
45		Parts catcher and box	○	○	○	○	○	○
46	Parts catcher and conveyor	○	○	○	○	○	○	
47	Standard devices	Front door interlock	●	●	●	●	●	●
48		Manual book	●	●	●	●	●	●
49		installation parts	●	●	●	●	●	●
50		safety sticker	●	●	●	●	●	●
51		Work light	●	●	●	●	●	●
52		Standard operation tools	●	●	●	●	●	●
53	Foot switch	●	●	●	●	●	●	
54	Optional devices	Tool monitoring system	○	○	○	○	○	○
55		Signal tower	○	○	○	○	○	○
56		Air gun	○	○	○	○	○	○
57		Auto power off	○	○	○	○	○	○

Peripheral Equipment

Basic information

Basic Structure  
Cutting  
Performance

Detailed Information

Options  
Applications  
Diagrams  
Specifications

Customer Support Service

Chip Conveyor (option 21~26)

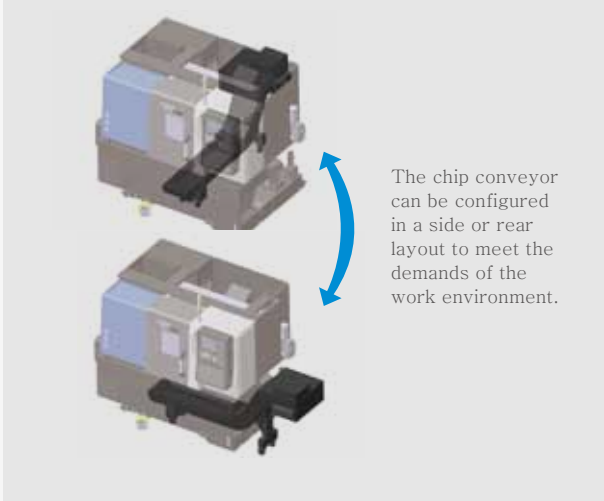

The chip conveyor can be configured in a side or rear layout to meet the demands of the work environment.

Chip conveyor type	Material	Description
Hinged belt	Steel	Most typical type of chip conveyor. Appropriate for steel materials generating chips of length of 30 mm or more.
Screw (auger)	Steel	Chip conveyor with smallest footprint. Demands 80% of footprint comparing to hinged belt.

Quick change CAPTO (option )



The Quick Change Tool system simplifies tool change operation. Recommended for users who need to change tools frequently or reduce the set-up time.

Grease Lubrication System



The standard grease lubrication system eliminates the need for an oil skimmer and reduces lubrication costs by about 80% compared to oil lubrication.

Yearly maintenance cost  
Max. **80%** ↓

Coolant Chiller (option 18)

The detachable coolant chiller is recommended to maintain thermal error at a minimal level and achieve superior machining precision.

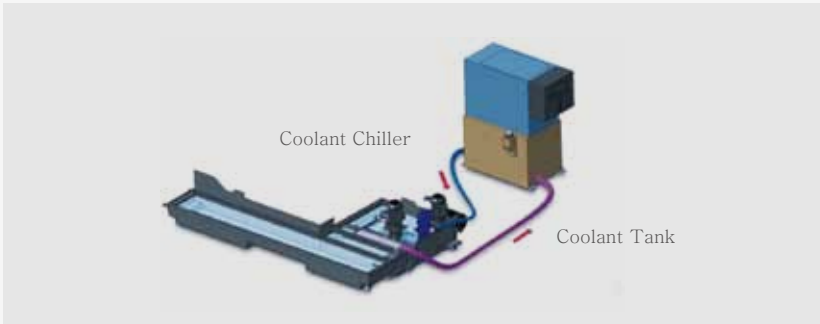

Easy-to-clean Coolant Tank

The coolant tank can be isolated without removing the chip conveyor, significantly enhancing the operator's convenience.

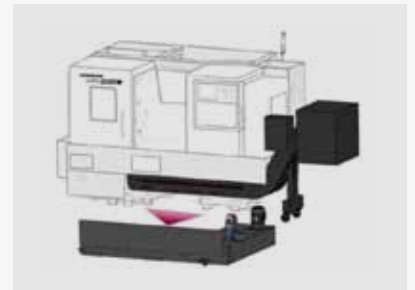

Tool Setter (Manual /Auto) (Tool length measurement device) (option 42~43)

The tool setter facilitates the setting of machining tools, and can be used to automatically compensate



Part Catcher (option 44~45)

The Part Catcher automatically catches finished parts and transfers them to the downstream processes.



Oil Skimmer (option 17)

As the Lynx 2100 Series uses a grease type lubricant, the coolant rarely mixes with oil. This optional oil skimmer helps keep exceptional service life of the coolant.



## DOOSAN FANUC i

CNC optimized for DOOSAN's machine tools maximizes productivity.

### User-Friendly Operation Panel

The newly-designed operation panel enhances operating convenience by incorporating common-design buttons and layout, and features the Qwerty keyboard for fast and easy



- 10.4-inch display**
  - Vertical soft key
- USB & PCMCIA card (standard)
- QWERTY keyboard
- Ez-guide i (standard)
- Ergonomically designed operation panel for greater user convenience
- Hot key



### Improved Productivity

Cycle time, mechanism operating speed, acceleration and deceleration are optimized and non-cutting times during cutting operation are analyzed and minimized to enhance productivity.

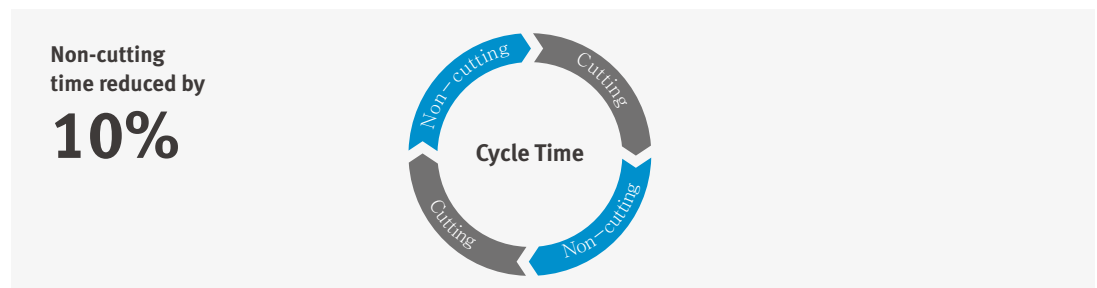

## SKETCH-TURN option



**DOOSAN Conversational programming software for PC**

- Easy to learn for beginners
- Time savings in programming
- Reduce processing cycle time

### EZ-Guide i

Using the DOOSAN EZ-Guide i, users can create a cutting program for any desired shape, including patterns, by entering the appropriate figures only.

#### Exemplary Programming

Cutting shape

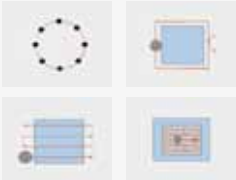

EZ-Guide i Screen



Enter the dimensions of the desired shape.

Automatic creation of cutting program

```

O7000 (SAMPLE PROGRAM) ;
...
M3 S1500 ;
G0 X50. Y125. ;
G0 Z30. ;
G1040 T0.5 J3. H0.2 K0.5 ... ;
G1020 H120. V50. U37. W68. ;
G0 Z80. ;
M5 ;
                    
```

A cutting program is automatically created with the

## Easy Operation Package

Doosan Easy Operation Package (EOP) supports the user with tool, help desk, operation, functionalities to maximize operational efficiency and user convenience.

### Basic information

Basic Structure  
Cutting  
Performance

### Detailed Information

Options  
Applications  
Diagrams  
Specifications

### Customer Support Service

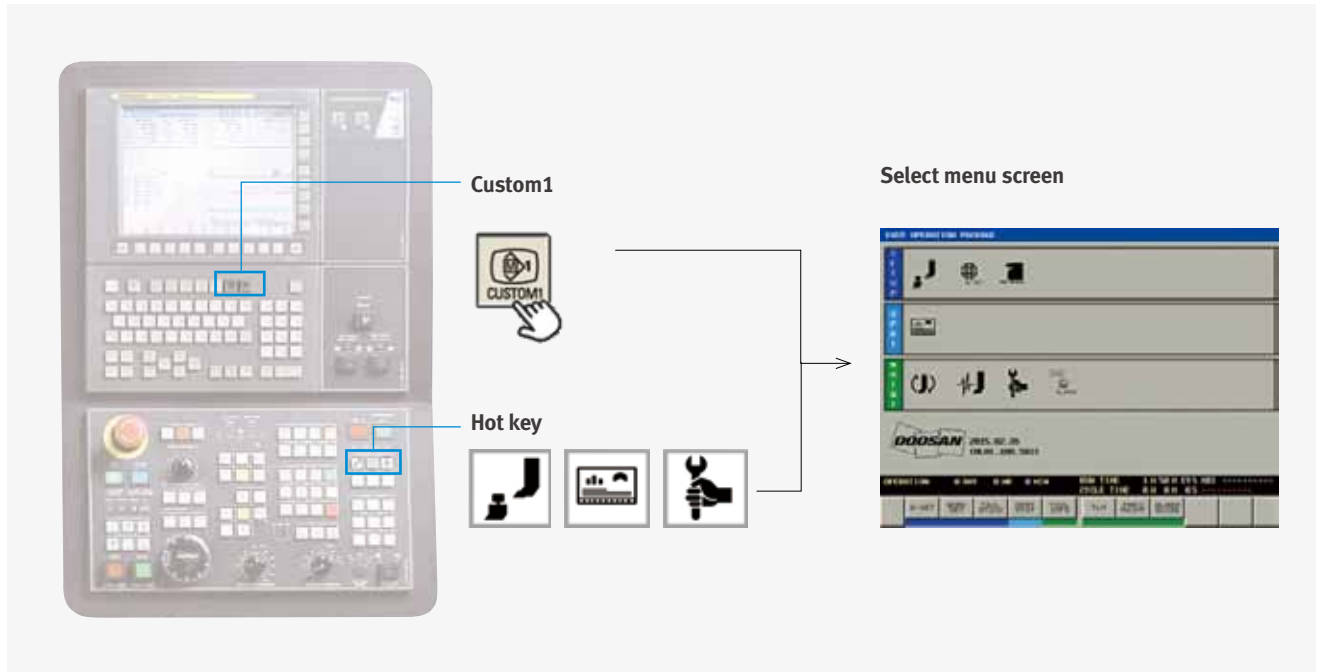

### Convenient set up for peripheral equipment

Helps tool setter guide, work setting, tailstock setting, and other measurement and parameter control to reduce setting-up time and facilitates operation.



### Screen for monitoring the machine and operating conditions

The screen provides a complete view of machine operation. Information on the feed system position, offset, feedrate and spindle speed, tool life and count in an easy-to-view screen.



### Management Convenience Screen

Helps to prepare tools and provides for visual information on alarms to reduce maintenance time.



SIEMENS CNC have been adopted and optimized for DOOSAN's machine tools to maximize users' productivity.

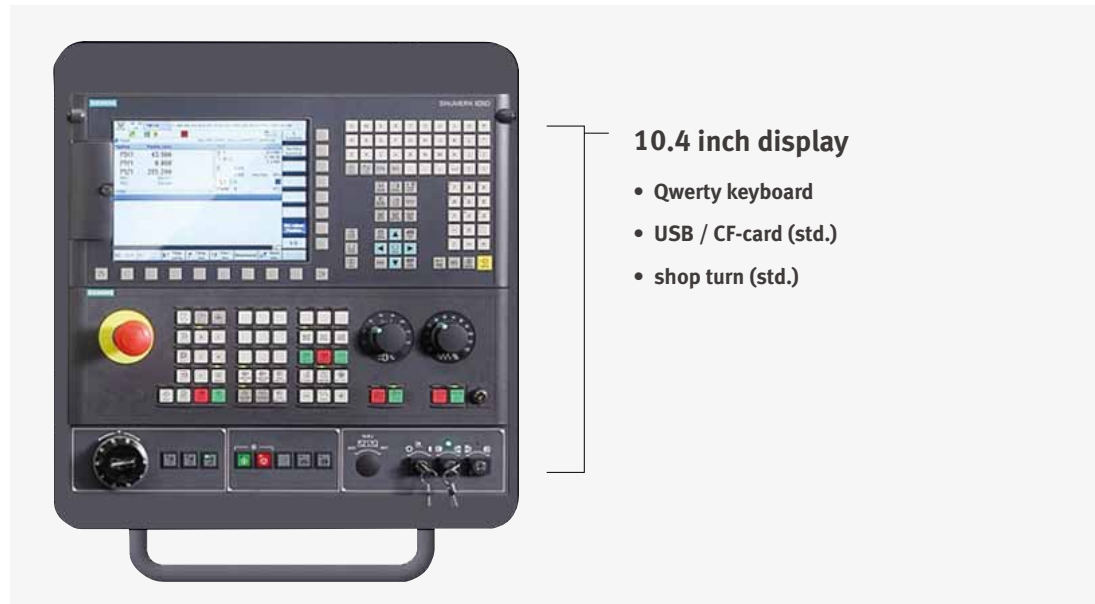

**10.4 inch display**

- Qwerty keyboard
- USB / CF-card (std.)
- shop turn (std.)

**Conversational Convenient function**

The machining monitoring function developed on the basis of the Shop Turn - an interactive machining support function of SIEMENS - provides users with cutting, servicing and maintenance screens for easy and convenient machine operation.

**Cutting and operation support function**

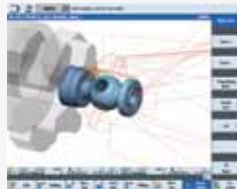

This function shows a cutting and tool path simulation of a cutting program on a real-time basis.

**Tail stock function**

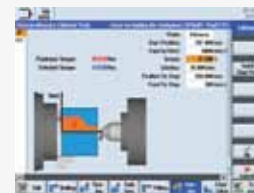

Dialogic Screen will help easy setting and operating about CNC Tail stock.

Shop-turn mode [various] → [attachments]

**Operation safety function**

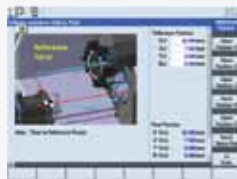

Spindle and Turret's interference could be checked before crash. So that it Protect operator's mistake.

[offset] → [operating parameter] → [attachment setting]

**Maintenance and service convenience function**



Maintenance and service of major units and peripheral devices, timer setting and parts counter setting can be easily carried out on a convenient screen.

[offset] → [operating parameter] → [TC service]

**Machining accuracy improvement**

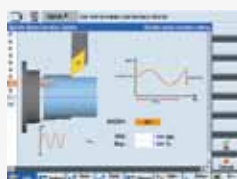

The NC controls spindle speed at an optimal level for precision threading and turning, making it possible to improve surface roughness automatically.

[various] → [attachment] → [DSSV]



Before applying the

After applying the

## Power-Torque Diagram (FANUC)

### Basic information

Basic Structure  
Cutting  
Performance

### Detailed Information

Options  
Applications  
Diagrams  
Specifications

### Customer Support Service

## Main Spindle

Lynx 2100A / LA / MA / LMA / LMSA

Speed **6000 r/min** Power **15/11 kW**  
(20.1/14.8 Hp)

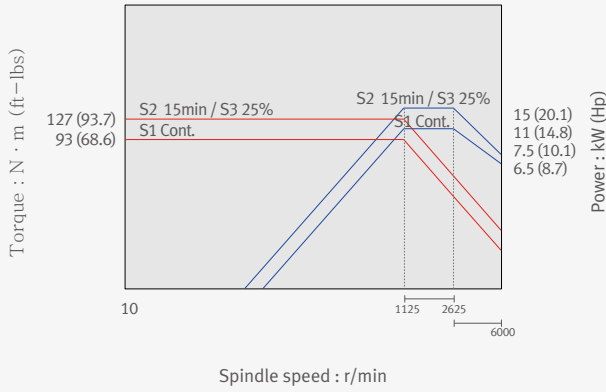

## Sub-Spindle

Lynx 2100LMSA / LMSB / LMSC

Speed **6000 r/min** Power **5.5/3.7 kW**  
(7.4/5.0 Hp)

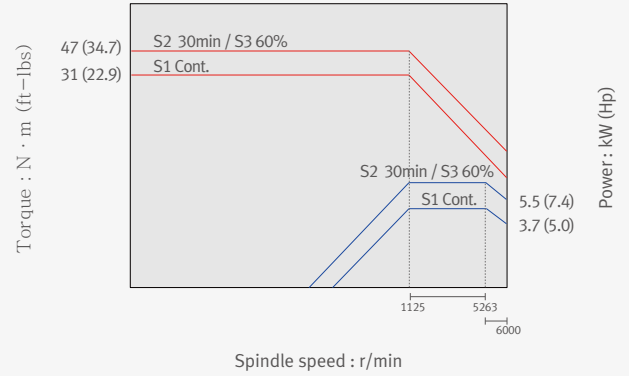

Lynx 2100B / LB / MB / LMB / LMSB

Speed **4500 r/min** Power **15/11 kW**  
(20.1/14.8 Hp)

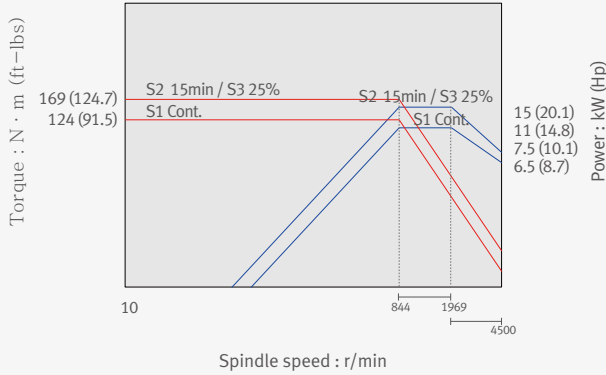

## Rotary Tool

Lynx 2100M / LM / LMS

Speed **6000 r/min** Power **3.7/1.1 kW**  
(5.0/1.5 Hp)

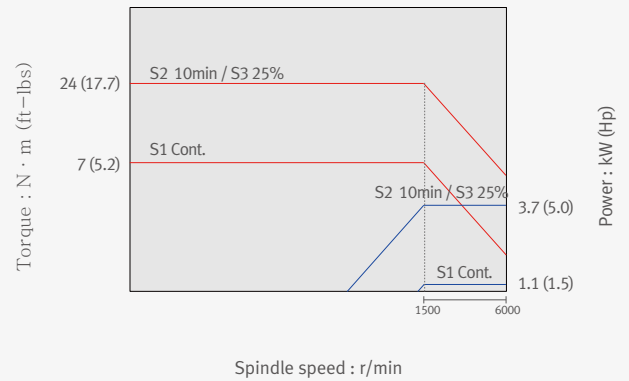

Lynx 2100LC / LMC / LMSC

Speed **3500 r/min** Power **18.5/15 kW**  
(24.8/20.1 Hp)

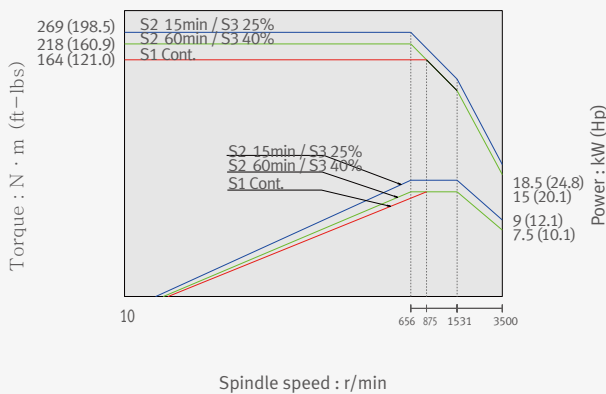

Lynx 2100M / LM / LMS **option**

Speed **10000 r/min** Power **3.7/1.1 kW**  
(5.0/1.5 Hp)

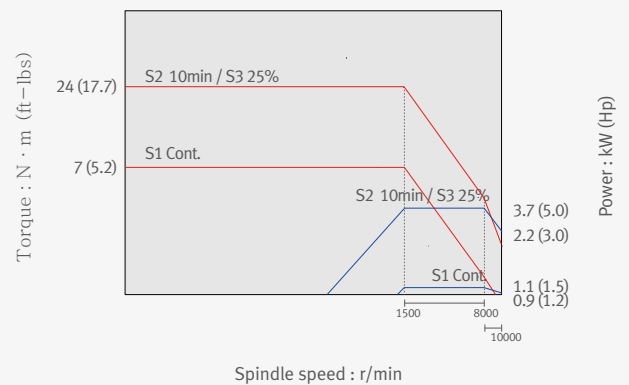

## Power-Torque Diagram (SIEMENS)

### Main Spindle

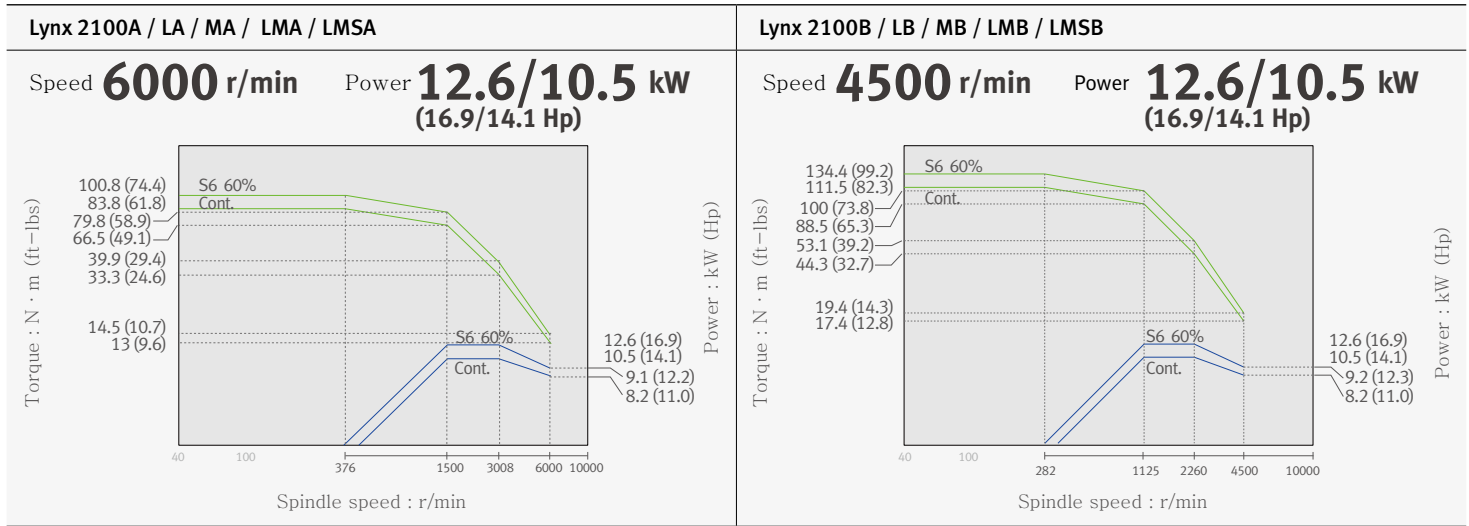

### Sub-Spindle

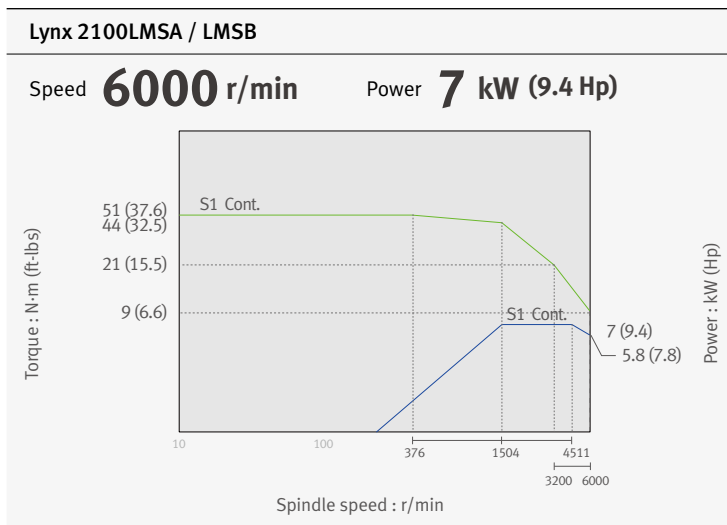

### Rotary Tool

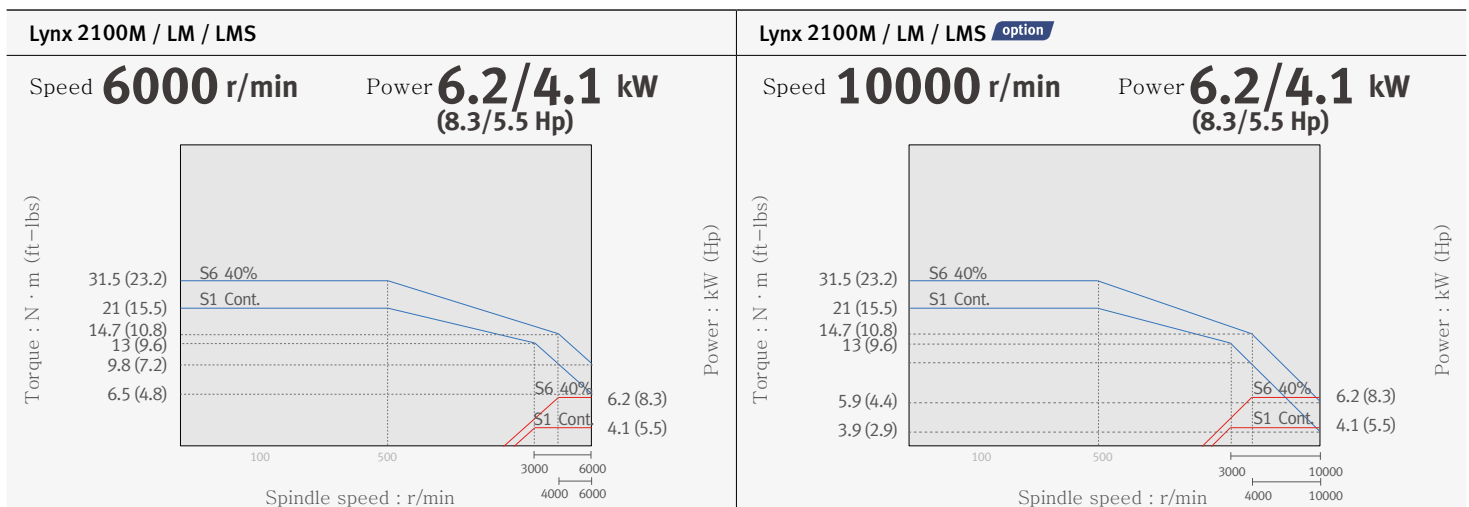

## External Dimensions

### Basic information

Basic Structure  
Cutting  
Performance

## Lynx 2100 series

Unit : mm (inch)

### Detailed Information

Options  
Applications  
Diagrams  
Specifications

### Customer Support Service

Top View

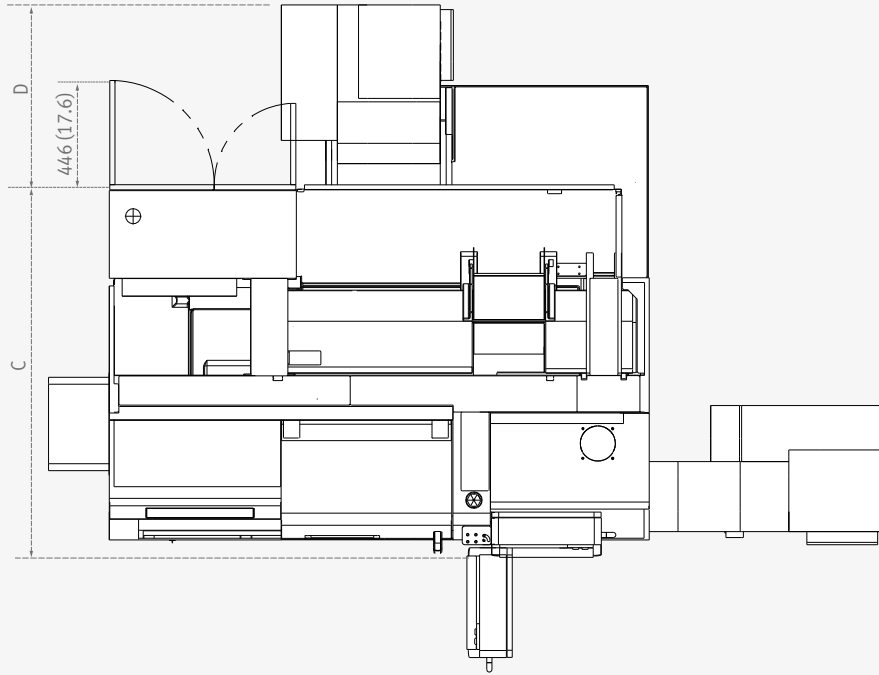

Front

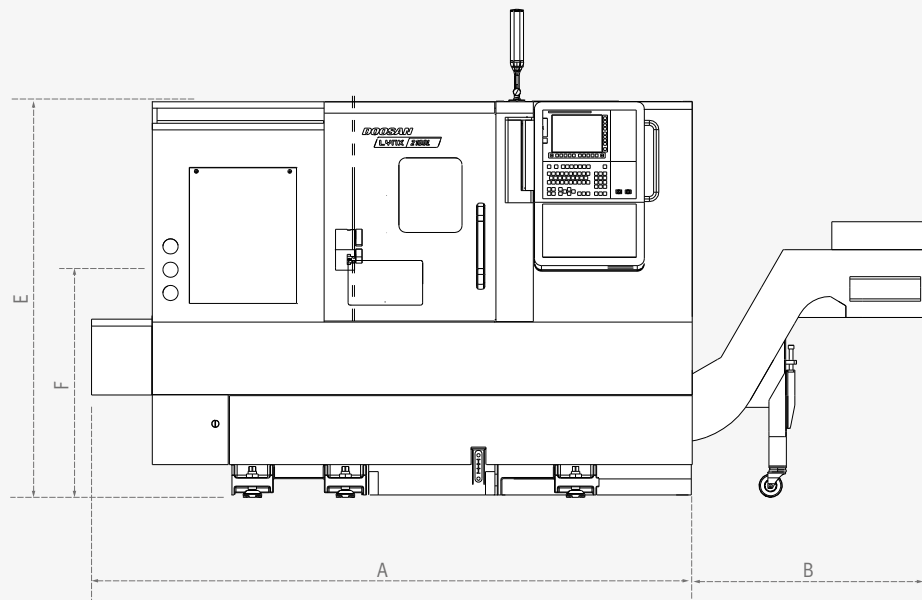

Models	A	B		C	D		E	F spindle center
		side hinged chip conveyor	side screw (auger) chip conveyor		rear hinged chip conveyor	rear screw (auger) chip conveyor		
Lynx 2100A / MA [B / MB]	2320 [2350] (91.3 [92.5])	953 (37.5)	759 (29.9)	1595 (62.8)	770 (30.3)	583 (23.0)	1693 (66.7)	1060 (41.7)
Lynx 2100LA / LMA [LB / LMB]	2540 [2570] (100.0 [101.2])	997 (39.3)	830 (32.7)	1595 (62.8)	770 (30.3)	616 (24.3)	1693 (66.7)	1070 (42.1)
Lynx 2100LC / LMC	2570 (101.2)	997 (39.3)	-	1602 (63.1)	770 (30.3)	-	1693 (66.7)	1060 (41.7)
Lynx 2100LMSA [LMSB]	2805 [2835] (110.4 [111.6])	997 (39.3)	830 (32.7)	1595 (62.8)	770 (30.3)	616 (24.3)	1693 (66.7)	1060 (41.7)
Lynx 2100LMSC	2837 (111.7)	993 (39.1)	-	1602 (63.1)	770 (30.3)	-	1693 (66.7)	1060 (41.7)

\* Some peripheral equipment can be placed in other places

# Tooling System

## Lynx 2100A / B / LA / LB / LC (10/12 station)

Unit : mm (inch)

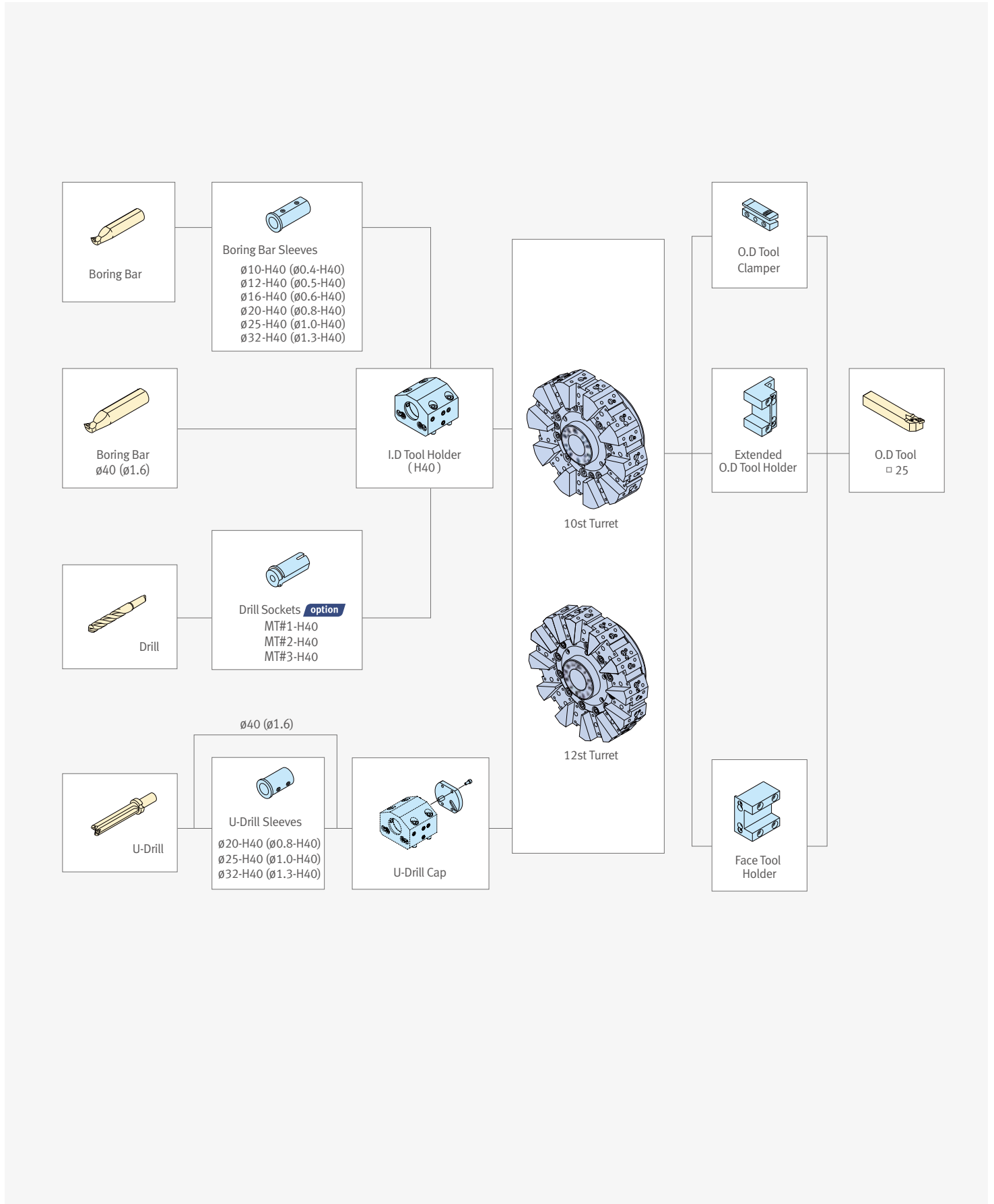

## Tooling System

### Basic information

Basic Structure  
Cutting  
Performance

### Lynx 2100MA / MB / LMA / LMB / LMC (12 station (24 Position Index), BMT45P)

Unit : mm (inch)

### Detailed Information

Options  
Applications  
Diagrams  
Specifications

### Customer Support Service

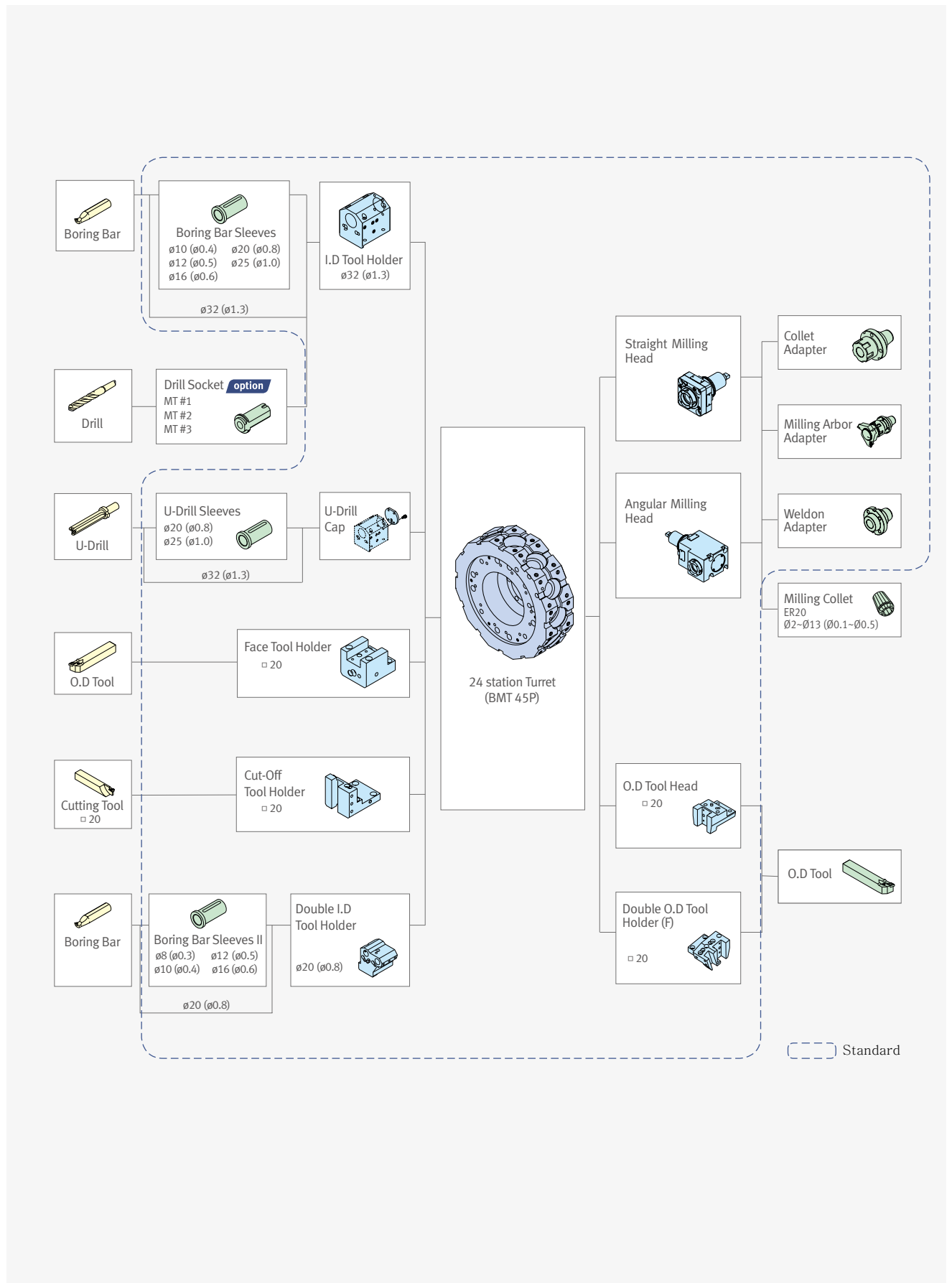

# Tooling System

## Lynx 2100LMSA / LMSB / LMSC (12 station (24 Position Index), BMT45P)

Unit : mm (inch)

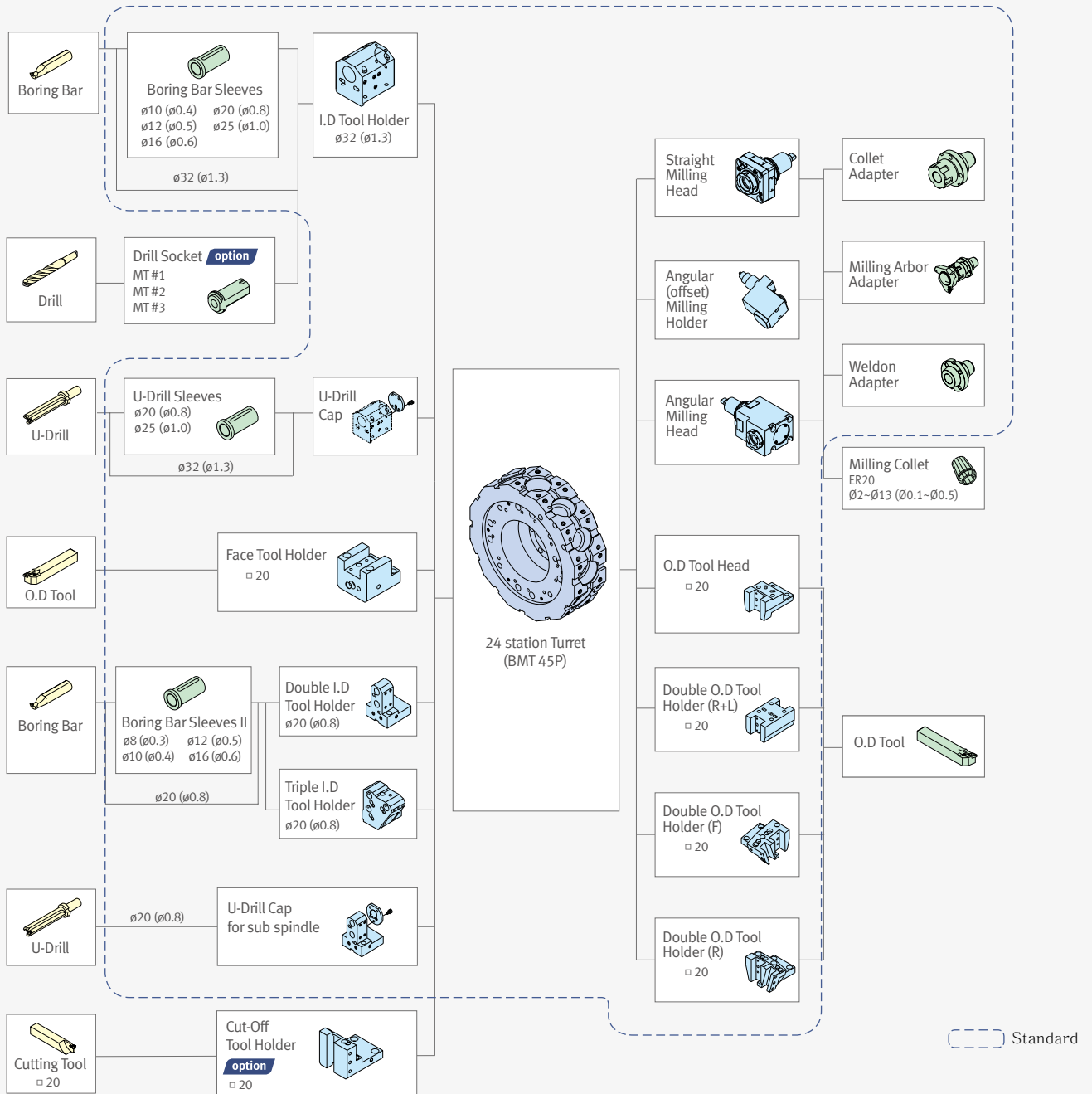



# Working Range

## Lynx 2100A / B [LA / LB / LC]

Unit : mm (inch)

OD Holder

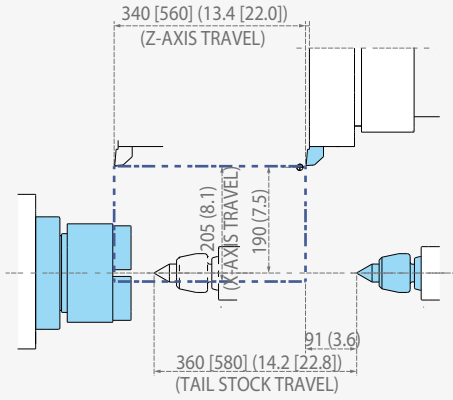

ID HOLDER

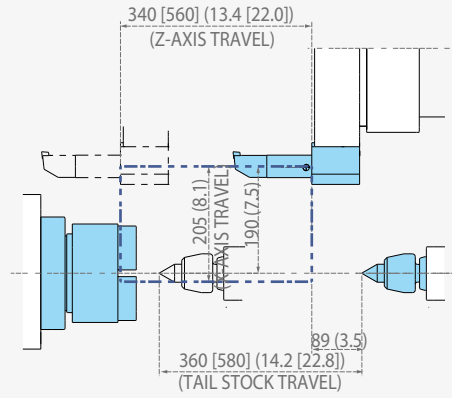

Face Tool Holder

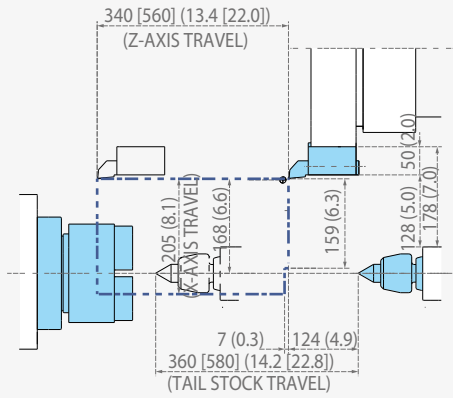

Extended OD Holder

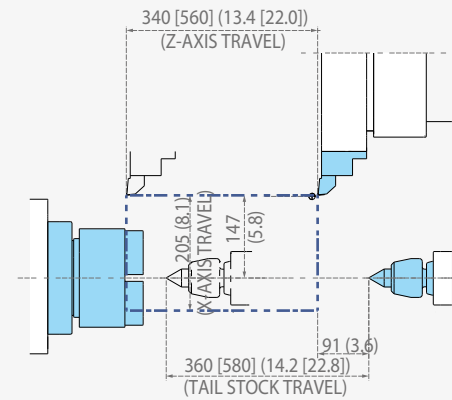

## Working Range

### Basic information

Basic Structure  
Cutting  
Performance

### Detailed Information

Options  
Applications  
Diagrams  
Specifications

### Customer Support Service

## Lynx 2100MA / MB [LMA / LMB / LMC]

Unit : mm (inch)

OD Holder

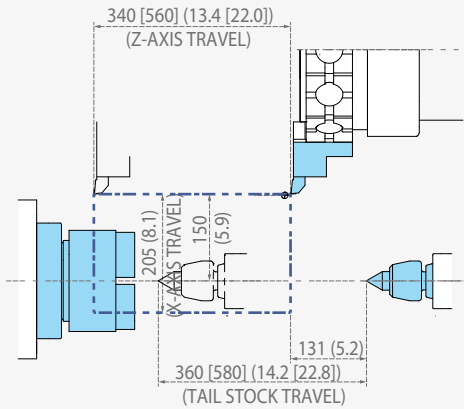

ID HOLDER

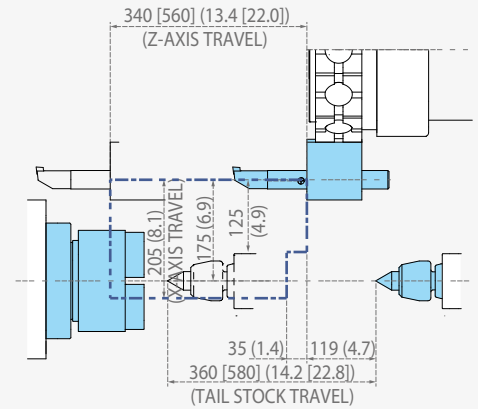

Face Tool Holder

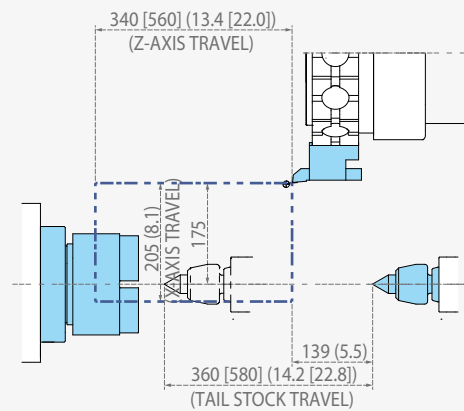

Double OD Holder

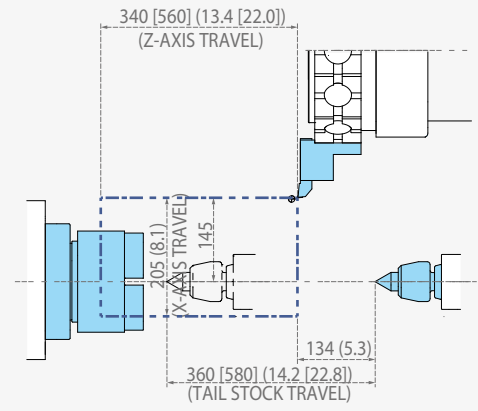

Straight Milling Holder

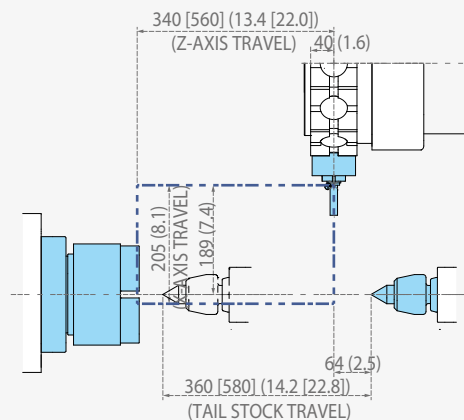

Angular Milling Holder

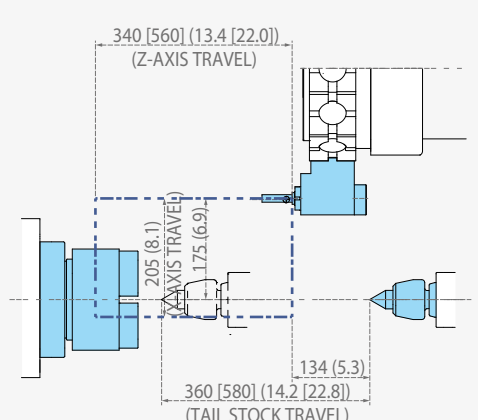

OD Holder

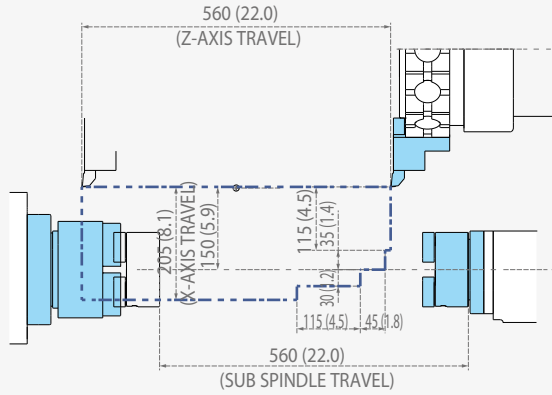

ID HOLDER

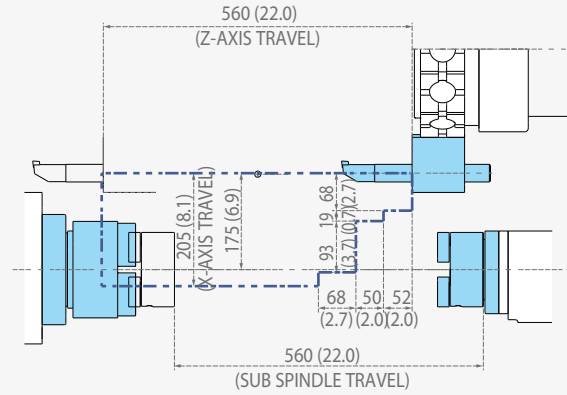

Double OD Holder

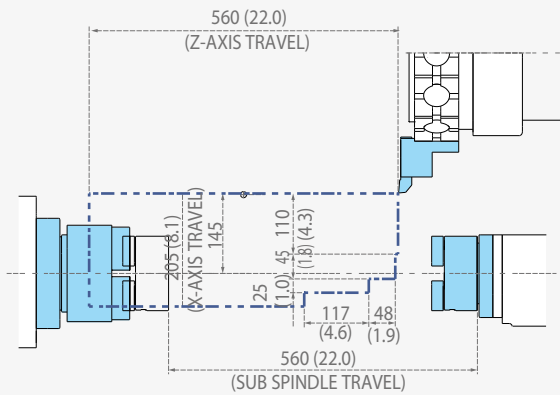

Face Tool Holder

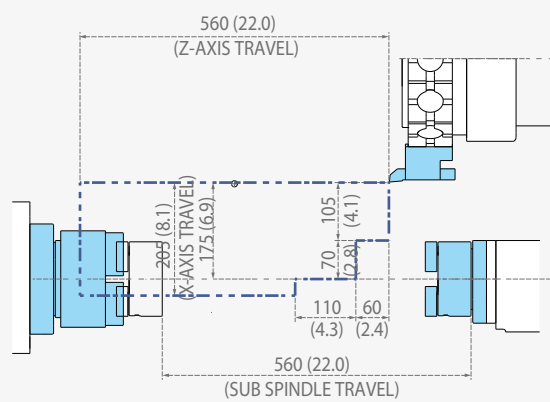

## Machine Specifications

## Basic information

Basic Structure  
Cutting  
Performance

## Detailed Information

Options  
Applications  
Diagrams  
Specifications

## Customer Support Service



Description		Unit	Lynx 2100A [LA]	Lynx 2100MA [LMA]
Capacity	Swing over bed	mm (inch)	600 (23.6)	
	Swing over saddle	mm (inch)	400 (15.7)	
	Recommended turning diameter	mm (inch)	170 (6.7)	
	Max. turning diameter	mm (inch)	350 (13.8)	300 (11.8)
	Max. turning length	mm (inch)	330 [550] (13.0 [21.7])	290 [510] (11.4 [20.1])
	Chuck size	inch	6 {8} *	
	Bar working diameter	mm (inch)	51 (2.0)	
Travel	Travel distance	X-axis	205 (8.1)	
		Z-axis	340 [560] (13.4 [22.0])	
Feedrate	Rapid traverse	X-axis	30 (1181.1)	
		Z-axis	36 (1417.3)	
Spindle	Spindle speed	r/min	6000	
	Spindle motor power (15min/cont.) (FANUC)	kW (Hp)	15/11 (20.1/14.8)	
	Spindle motor power (S6 60%/cont.) (SIEMENS)	kW (Hp)	12.6/10.5 (16.9/14.1)	
	Max. spindle torque (FANUC)	N-m (ft-lbs)	127 (93.7)	
	Max. spindle torque (SIEMENS)	N-m (ft-lbs)	100.8 (74.4)	
	Spindel nose	ASA	A2-5	
	Spindle bearing diameter	mm (inch)	90 (3.5)	
	Spindle inner diameter	mm (inch)	61 (2.4)	
	C-axis min.indexing angle	deg	-	0.001
Turret	No.of tool stations	ea	12 {10} *	12
	OD tool size	mm (inch)	25 x 25 (1.0 x 1.0)	20 x 20 (0.8 x 0.8)
	Max.ID tool size	mm (inch)	40 (1.6)	32 (1.3)
	Turret indexing time	s	0.11 {0.15} *	0.11
	Max.rotary tool speed	r/min	-	6000 {10000} *
	Ratary tool motor power (FANUC)	kW (Hp)	-	3.7 (5.0)
	Rotary tool motor power (SIEMENS)	kW (Hp)	-	6.2 (8.3)
Tail stock	Travel distance	mm (inch)	360 [580] (14.1 [22.8])	360 [580] (14.1 [22.8])
	Quill diameter	mm (inch)	65 (2.6)	65 (2.6)
	Quill taper	MT	MT#4 (Live)	MT#4 (Live)
Sub spindle	Spindle speed		-	-
	Spindle motor power (15min/cont.) (FANUC)	kW (Hp)	-	-
	Spindle motor power (cont.) (SIEMENS)	kW (Hp)	-	-
	Max. spindle torque	N-m (ft-lbs)	-	-
	Spindel nose		-	-
	Spindle bearing diameter	mm (inch)	-	-
	Spindle inner diameter	mm (inch)	-	-
C-axis min.indexing angle		-	-	
Power source	Power consumption	kVA	25.94	25.94
Machine dimensions	Length	mm (inch)	2320 [2540] (91.3 [100.0])	2320 [2540] (91.3 [100.0])
	Width	mm (inch)	1595 (62.8)	
	Height	mm (inch)	1693 (66.7)	
	Weight	kg (lb)	3100 [3400] (6834.2 [7495.6])	3170 [3480] (6988.6 [7672.0])
Control	NC system		DOOSAN-FANUC i / SIEMENS 828D	

Lynx 2100LMSA	Lynx 2100B [LB]	Lynx 2100MB [LMB]	Lynx 2100LMSB	Lynx 2100LC	Lynx 2100LMC	Lynx 2100LMSC
600 (23.6)			600 (23.6)			
400 (15.7)			400 (15.7)			
170 (6.7)			255 (10.0)			
300 (11.8)	350 (13.8)	300 (11.8)	300 (11.8)	350 (13.8)	300 (11.8)	300 (11.8)
510 (20.1)	330 [550] (13.0 [21.7])	290 [510] (11.4 [20.1])	510 (20.1)	537 (21.1)	497 (19.6)	497 (19.6)
6 {8}*	8 {10}*			10		
51 (2.0)	65 (2.6)			81 (3.2)		
205 (8.1)			205 (8.1)			
340 [560] (13.4 [22.0])			560 (22.0)			
30 (1181.1)			30 (1181.1)			
36 (1417.3)			36 (1417.3)			
6000	4500			3500		
15/11 (20.1/14.8)			18.5/15 (24.8/20.1)			
12.6/10.5 (16.9/14.1)			**			
127 (93.7)	169 (124.6)			269 (198.5)		
100.8 (74.4)	134.4 (99.2)			**		
A2-5	A2-6			A2-8		
90 (3.5)	110 (4.3)			130 (5.1)		
61 (2.4)	76 (3.0)			91 (3.6)		
0.001	-	0.001	0.001	-	0.001	0.001
12	10 {12}*	12	12	10	12	12
20 x 20 (0.8 x 0.8)	25 x 25 (1.0 x 1.0)	20 x 20 (0.8 x 0.8)	20 x 20 (0.8 x 0.8)	25 x 25 (1.0 x 1.0)	20 x 20 (0.8 x 0.8)	20 x 20 (0.8 x 0.8)
32 (1.3)	40 (1.6)	32 (1.3)	32 (1.3)	40 (1.6)	32 (1.3)	32 (1.3)
0.11	0.15 {0.11}*	0.11	0.11	0.15	0.11	0.11
6000 {10000}*	-	6000 {10000}*	6000 {10000}*	-	6000 {10000}*	6000 {10000}*
3.7 (5.0)	-	3.7 (5.0)	3.7 (5.0)	-	3.7 (5.0)	3.7 (5.0)
6.2 (8.3)	-	6.2 (8.3)	6.2 (8.3)	**		
-	360 [580] (14.1 [22.8])	360 [580] (14.1 [22.8])	-	580 (22.8)	580 (22.8)	-
-	65 (2.6)	65 (2.6)	-	65 (2.6)	65 (2.6)	-
-	MT#4 (Live)	MT#4 (Live)	-	MT#4 (Live)	MT#4 (Live)	-
6000	-	-	6000	-	-	6000
5.5/3.7 (7.4/5.0)	-	-	5.5/3.7 (7.4/5.0)	-	-	5.5/3.7 (7.4/5.0)
7 (9.4)	-	-	7 (9.4)	**		
47 (34.7)	-	-	47 (34.7)	-	-	47 (34.7)
Flat $\phi$ 110	-	-	Flat $\phi$ 110	-	-	Flat $\phi$ 110
75 (3.0)	-	-	75 (3.0)	-	-	75 (3.0)
43 (1.7)	-	-	43 (1.7)	-	-	43 (1.7)
0.001	-	-	0.001	-	-	0.001
31.8	25.94	25.94	31.8	32.81	32.81	34.84
2805 (110.4)	2350 [2570] (92.5 [101.2])	2350 [2570] (92.5 [101.2])	2835 (111.6)	2570 (101.2)	2570 (101.2)	2837 (111.7)
1595 (62.8)			1602 (63.1)			
1693 (66.7)			1693 (66.7)			
3600 (7936.5)	3100 [3400] (6834.2 [7495.6])	3170 [3480] (6988.6 [7672.0])	3600 (7936.5)	3500 (7716.1)	3580 (7892.4)	3800 (8377.4)
DOOSAN-FANUC i / SIEMENS 828D				DOOSAN-FANUC i / SIEMENS 828D		

Basic information

Basic Structure  
Cutting  
Performance

Detailed Information

Options  
Applications  
Diagrams  
Specifications

Customer Support Service

DOOSAN  
FANUC i

NO.	Division	Item	Spec.	DOOSAN-FANUC i		
				2-axis	M	MS
				A / B / LA / LB / LC	MA / MB / LMA / LMB / LMC	MSA / MSB / MSC
1		Controlled axes	X, Z	X, Z, C	X, Z, C, B	
2		Simultaneously controlled axes	2 axes	3 axes	4 axes	
3		Cs contouring control	x	●	●	
4		Synchronous / Composite control	x	x	○	
5		Torque control	●	●	●	
6		HRV2 control	●	●	●	
7		Inch / metric conversion	●	●	●	
8		Stored stroke check 1	●	●	●	
9		Stored stroke check 2,3	●	●	●	
10		Stored limit check before move	●	●	●	
11		Chamfering on / off	●	●	●	
12		Unexpected disturbance torque detection function	●	●	●	
13		Position switch	●	●	●	
14		DNC operation	Included in RS232C interface.	●	●	
15		DNC operation with memory card		●	●	
16		Quick program restart		○	○	
17		Tool retract and recover		○	○	
18		Wrong operation prevention		●	●	
19		Dry run		●	●	
20		Single block		●	●	
21		Reference position shift		●	●	
22		Handle interruption		○	○	
23		Incremental feed	x1,x10,x100	●	●	
24		Manual handle retrace		○	○	
25		Nano interpolation		●	●	
26		Linear interpolation		●	●	
27		Circular interpolation		●	●	
28		Polar coordinate interpolation		x	●	
29		Cylindrical interpolation		x	●	
30		Helical interpolation		x	○	
31		Thread cutting, synchronous cutting		●	●	
32		Multi threading		●	●	
33		Thread cutting retract		●	●	
34		Continuous threading		●	●	
35		Variable lead thread cutting		●	●	
36		Polygon machining with two spindles		x	●	
37		High-speed skip	Input signal is 8 points.	○	○	
38		2nd reference position return	G30	●	●	
39		3rd / 4th reference position return		●	●	
40		Override cancel		●	●	
41	Feed function	AI contour control I		○	○	
42		AI contour control II		○	○	
43		Rapid traverse block overlap		●	●	
44	Program input	Optional block skip	9 pieces	●	●	
45		Absolute / incremental programming	Combined use in the same block	●	●	
46		Diameter / Radius programming		●	●	

NO.	Division	Item	Spec.	DOOSAN-FANUC i		
				2-axis	M	MS
				A / B / LA / LB / LC	MA / MB / LMA / LMB / LMC	MSA / MSB / MSC
47	Program input	Automatic coordinate system setting		●	●	●
48		Workpiece coordinate system	G52 – G59	●	●	●
49		Workpiece coordinate system preset		●	●	●
50		Direct drawing dimension programming		●	●	●
51		G code system	A	●	●	●
52		G code system	B/C	●	●	●
53		Chamfering / Corner R		●	●	●
54		Custom macro		●	●	●
55		Addition of custom macro common variables	#100 – #199, #500 – #999	●	●	●
56		Interruption type custom macro		●	●	●
57		Canned cycle		●	●	●
58		Multiple repetitive cycles	G70~G76	●	●	●
59		Multiple repetitive cycles II	Pocket profile	●	●	●
60		Canned cycle for drilling		●	●	●
61		Coordinate system shift		●	●	●
62	Direct input of coordinate system shift		●	●	●	
63	Pattern data input		●	●	●	
64	Operation Guidance Function	EZ Guidei(Conversational Programming Solution)		●	●	●
65		EZ Operation package		●	●	●
66	Auxiliary / Spindle speed function	Constant surface speed control		●	●	●
67		Spindle override	0 – 150%	●	●	●
68		Spindle orientation		●	●	●
69		Spindle synchronous control		x	x	●
70		Rigid tap		●	●	●
71	Arbitrary speed threading		○	○	○	
72	Tool function / Tool compensation	Tool offset pairs	128–pairs	●	●	●
73		Tool offset pairs	200–pairs	○	○	○
74		Tool offset		●	●	●
75		Tool radius / Tool nose radius compensation		●	●	●
76		Tool geometry / wear compensation		●	●	●
77		Automatic tool offset	G36/G37	●	●	●
78		Direct input of offset value measured B		●	●	●
79	Tool life management		●	●	●	
80	Accuracy compensation function	Backlash compensation for each rapid traverse and cutting feed		●	●	●
81		Stored pitch error compensation		○	○	○
82	Editing operation	Part program storage size & Number of registerable programs	5120M(2MB)_1000 programs	○	○	○
83		Part program storage size & Number of registerable programs	1280M(512KB)_400 programs	●	●	●
84		Part program storage size & Number of registerable programs	5120M(2MB)_400 programs	○	○	○
85		Program protect		●	●	●
86		Password function		●	●	●
87	Playback		●	●	●	
88	Setting and display	Main menu screen		●	●	●
89	Data input / output	Fast data server		○	○	○
90		External data input		●	●	●
91		Memory card input / output		●	●	●
92		USB memory input / output		●	●	●
93	Automatic data backup		●	●	●	
94	Interface function	Embedded Ethernet		●	●	●
95		Fast Ethernet		○	○	○

## Basic information

Basic Structure  
Cutting  
Performance

## Detailed Information

Options  
Applications  
Diagrams  
Specifications

## Customer Support Service

# SIEMENS

## S828D

NO.	Division	Item	Spec.	S828D
				Lynx 2100 series
1		Controlled axes R: Milling spindle	2 axis	X, Z, SP
			M-type	X, Z, C, R
			S-type	X, Z, C, C2, B
			MS-type	X, Z, C, R, C2, B
2		Simultaneously controlled axes	Positioning (G00) / Linear interpolation (G01) : 3 axes Circular interpolation (G02, G03) : 2 axes	●
3		Backlash compensation		●
4	Control axes	Leadscrew error compensation		●
5		Measuring system error compensation		●
6		Feedforward control	velocity-dependent	●
7		Follow up mode		●
8		Programmable acceleration		●
9		Emergency stop / overtravel		●
10		Least command increment	0.001mm (0.0001 inch)	●
11		Least input increment	0.001mm (0.0001 inch)	●
12		Maximum commandable value	±99999.999mm (±3937 inch)	●
13		Machine lock		●
14	Absolute encoder		●	
15		Reference point return	G75 FP=1	●
16		2nd reference point return	G75 FP=2	●
17		3rd / 4th reference return	G75 FP=3, 4	●
18		Linear interpolation	Max. 4	●
19		Circular interpolation	G02, G03	●
20		Inverse time feedrate	G93	●
21		Helical interpolation		●
22		Universal interpolator NURBS		●
23		Spline interpolation (A, B and C splines)		○
24		Dwell	G04	●
25		Feedrate / Rapid override	0 - 120 %	●
26		Separate path feed for corners and chamfers		●
27		Manual handle feed (1unit)	Portable manual pulse generator	●
28		Reposition		●
29		Acceleration with Jerklimitation		●
30		Spindle speed override	50 - 120 %	●
31	Spindle function	Spindle speed limitation		●
32		Retraction for rigid tapping		●
33		Rigid tapping		●
34	Tool function	<b>Tool radius compensations in plane</b>		
35		• With approach and retract strategies		●
36		• With transition circle / ellipse on outer edges		●
37		Number of tools / cutting edges in tool list		256 / 512
38		Tool length compensation		●
39		Operation with tool management		●
40		Tool list		●
41		Replacement tools for tool management		○
42		Monitoring of tool life and workpiece count		●
43		Manual measurement of tool offset		●
44		Loading and unloading of tools		●

● Standard ○ Optional X Not applicable

NO.	Division	Item	Spec.	S828D
				Lynx 2100 series
57	Programming & Editing function	• Geometry axes, switchable online in the CNC program		●
58		• Program preprocessing		●
59		Online ISO dialect interpreter		●
60		<b>Program / workpiece management</b>		
61		• Parts programs on NCU, max. number		300
62		• Workpieces on NCU, max. number		100
63		• On additional plug-in CF card		●
64		• On USB storage medium (e.g. disk drive, USB stick)		●
65		• On network drive		○
66		Settable offsets, max. number	G54, G55, G56 ...	100
67		<b>Program editor</b>		
68		• Programming support for cycles program(Program Guide)		●
69		• CNC editor with editing functions: Marking, copying, deleting		●
70		• Programming graphics / free contour input (contour calculator)		●
71		• Support for parameter input Animated Elements		●
72		• ShopTurn / ShopMill Machining step programming		●
73		Technology cycles for drilling/milling		●
74		Pocket milling free contour and islands stock removal cycle		●
75		Residual material detection		●
76		Access protection for cycles		●
77	Programming support can be extended, e.g. customer cycles		●	
78	2D simulation		●	
79	3D simulation, finished part		●	
80	Simultaneous recording		●	

## Major Specifications

### Lynx 2100 series



Description	Unit	Lynx 2100 [L]	Lynx 2100M [LM] [LMS]
Max. turning dia.	mm (inch)	Ø350 (Ø13.8)	Ø300 (Ø11.8)
Max. turning length	mm (inch)	330 [550] <sup>*1</sup> (13.0 [21.7])	290 [510] [510] <sup>*2</sup> (11.4 [20.1] [20.1])
Standard chuck size	inch	6 / 8 / 10	
Max. spindle speed	r/min	6000 / 4500 / 3500	
Max. spindle power	kW (Hp)	15 (20.1) <sup>*3</sup>	

\*1 : 537 mm (21.1 inch) (Lynx 2100LC)

\*2 : 497 mm (19.6 inch) (Lynx 2100LMC, LMSC)

\*3 : 18.5 kW (24.8 Hp) (Lynx 2100LC, LMC, LMSC)

## Doosan Machine Tools

\* For more details, please contact Doosan Machine Tools.

\* The specifications and information above-mentioned may be changed without prior notice.

\* Doosan Machine Tools Co., Ltd. is a subsidiary of MBK Partners. The trademark **DOOSAN** is used under a licensing agreement with Doosan Corporation, the registered trademark holder.

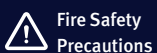

**Fire Safety  
Precautions**

There is a high risk of fire when using non-water-soluble cutting fluids, processing flammable materials, neglecting use coolants and modifying the machine without the consent of the manufacturer. Please check the SAFETY GUIDANCE carefully before using the machine.